

Curtain Transvectors®

Air Knives Deliver Flat Sheet of Amplified Air



ITW Vortec Curtain Transvector® Air Knives efficiently blowoff wide surfaces of debris as well as provide high speed drying or cooling for a broad range of industrial applications. Ionizing Curtain Transvectors® add a Static Neutralizing Bar to kill static cling and discharge dust and particles for blowoff.

Since Curtain Transvectors® are air amplifiers, they use a small amount of compressed air to deliver a powerful, high velocity, laminar sheet of air over wide areas such as moving webs, film, sheets, strips, auto bodies and other large assemblies and objects. Our patented design produces increased thrust and velocity, reduced noise, excellent uniformity, and significantly outperforms any competing, wide blowoff device. Stainless steel models are ideal for food, pharmaceutical, chemical and other applications where purity, high temperatures or corrosive environments are concerned.

Curtain Transvectors®, as well as the ionizing versions, have numerous and diverse processing, finishing, fabrication, assembly, and other industrial uses for cooling, drying, cleaning or static removal on wide surfaces, including:

- Food processing
- Shrink wrapping
- Clean room procedures
- Form and fill
- Films and plastics
- Textiles
- Printing and labeling
- Converting and packaging
- Woodworking and laminates
- Paint preparation and drying
- Sheet and web materials
- Conveying or hold down

Effective cleaning of dust, shavings and debris, may require discharge of static cling to blow away unwanted particles. The Ionizing Curtain Transvector's Static Neutralizing Bar generates positive and negative charged ions that are carried to your product in a uniform sheet of amplified air.

Power Supply Units:

A power supply unit is required to operate Ionizing Curtain Transvectors. Based on the number of ionizing bars needed, choose from two or four-cable models, both rated at 115V, 50/60Hz input; 7.0kV output.

MODEL		MODEL	
F167	2 cable model	D167RY	4 cable model

- High performance patented design
- Fraction of the cost of fans and blowers
- No guards or rotating machinery
- Instant on/off – output air easily regulated
- Compact and easily mounted
- No moving parts – maintenance free
- Quiet – meets OSHA noise specifications



Curtain Transvector Models:

OAL – Overall Length

EFFECTIVE LENGTH	ALUMINUM		STAINLESS STEEL		IONIZING	
	MODEL	OAL (mm)	MODEL	OAL (mm)	MODEL	OAL (mm)
3"	921-3	3 11/32" (85)	–	–	–	–
6"	921-6	6 11/32" (161)	921SS	6 3/16" (157)	981-6	7" (178)
12"	921-12	12 11/32" (313)	922SS	12 3/16" (310)	981-12	13" (330)
18"	921-18	18 11/32" (466)	924SS	18 3/16" (462)	981-18	19" (483)
24"	921-24	24 11/32" (618)	923SS	24 3/16" (614)	981-24	25" (635)

Cool, Clean, Dry or Kill Static While Reducing Air Consumption and Noise



ITW Vortec
Innovative Compressed Air Technologies

Dimensions – Aluminum Curtain Transvectors

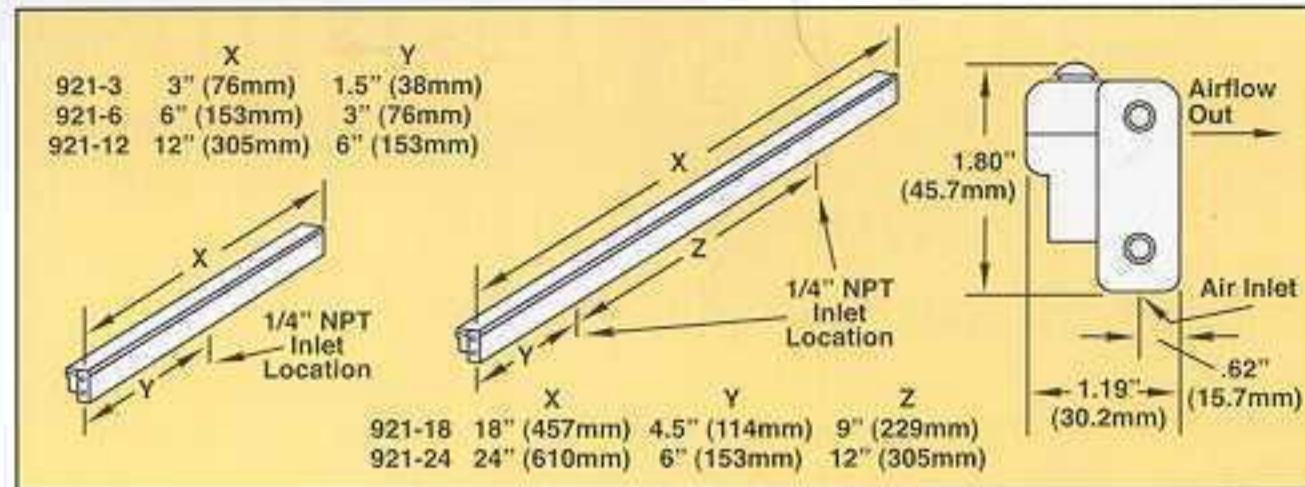

Curtain Transvector/Ionizing Curtain Transvector Performance Specifications

PRESSURE PSIG	AIR CONSUMPTION (SCFM)					VELOCITY AT DISTANCE FROM OUTLET (FT./MIN.)			THRUST* PER IN. OZ.
	3" (TRANSVECTOR LENGTH)	6"	12"	18"	24"	2"	6"	12"	
30	6	11	23	34	45	12,500	5,100	3,700	1.2
40	7	14	29	43	58	14,400	7,100	4,600	1.7
50	9	17	35	52	70	16,200	8,400	5,800	2.3
60	10	20	40	60	80	17,000	9,900	6,700	2.8
70	12	23	46	69	92	17,800	10,600	7,600	3.4
80	13	26	52	78	104	18,600	12,200	8,400	3.9
90	14	29	57	86	114	19,400	13,200	9,200	4.4
100	16	32	64	95	127	20,200	14,200	10,000	4.9

* At 12" from Curtain Transvector outlet (e.g. a 12" Curtain Transvector at 50 PSIG will produce 2.3 x 12 = 27.6 oz. of thrust.)

PRESSURE BAR	AIR CONSUMPTION (SLFM)					VELOCITY AT DISTANCE FROM OUTLET (M/S)			THRUST* PER CM. (G)
	7.6CM (TRANSVECTOR LENGTH)	15CM	31CM	46CM	61CM	5CM	15CM	31CM	
2.1	162	323	642	965	1285	64	26	19	14
2.8	204	408	815	1223	1630	73	36	23	19
3.5	246	492	985	1477	1970	82	43	29	25
4.1	284	569	1138	1707	2275	86	50	34	31
4.8	325	651	1302	1953	2604	90	54	39	38
5.5	368	736	1472	2207	2943	94	62	43	44
6.2	404	807	1613	2420	3226	99	67	47	49
6.9	450	900	1800	2700	3600	103	72	51	55

* At 30° from Curtain Transvector outlet.



KNIGHT PNEUMATICS PTY. LTD.

74 LEILA ROAD
CARNEGIE VIC 3163

Tel: 9576 8044 - Fax: 9576 8099

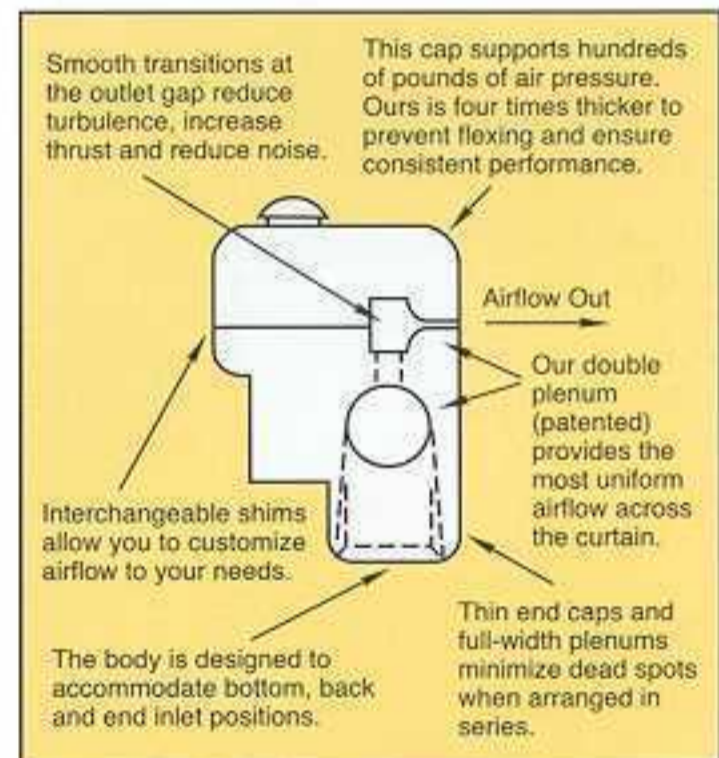

ITW Vortec
Innovative Compressed Air Technologies

Knight Pneumatics
74 Leila Road
Carnegie Vic 3163
Ph: 03 9576 8044
Fax: 03 9576 8099

e-mail: sales@knightpneumatics.com.au

Reference the Product Guide catalog and/or ITW Vortec invoice Conditions of Sale for complete information and warranty terms. Due to a policy of continuous development we reserve the right to change specifications without notice.