



# Style L



## Vacuum Cups

### Style L

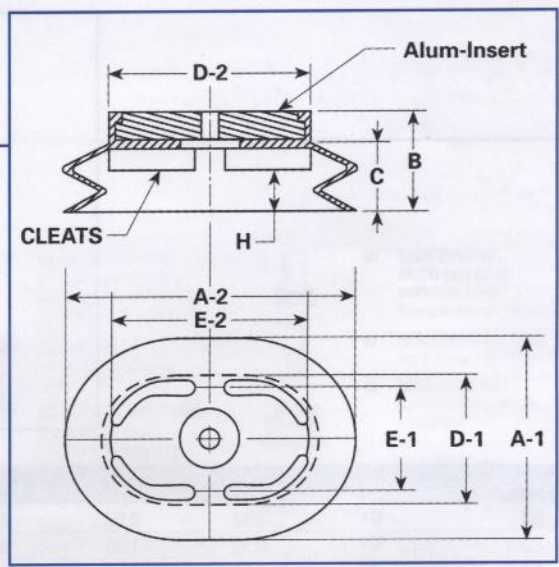

### Style L Includes A-1 (oval cup)

STYLE = Number of Convolutions

VC No.	Style	A-1	A-2	B	C	D-1	D-2	E-1	E-2	H	Cleats
32 3.5 x 10	D1	3.50	10.00	1.77	1.25	2.00	8.50	1.81	8.31	0.75	YES
32 3.5 x 5	D1	3.45	4.93	1.75	1.25	1.40	2.45	1.82	3.35	0.68	YES
129	D2	3.25	7.87	2.00	1.56	2.20	6.87	2.28	6.93	1.18	YES
32 3 x 3.25	D4	3.00	3.25	2.75	2.25	2.50	2.75	1.75	1.94	2.03	YES
32 3 x 7	D4	3.00	7.00	2.50	1.94	1.88	5.88	2.09	6.09	1.81	YES
32 2.75 x 6.5	D2	2.75	6.50	2.50	1.98	1.61	5.36	1.24	4.99	1.69	YES
32 2.5 x 6DP	D4	2.50	6.00	3.84	1.12	1.37	4.87	1.00	4.50	2.00	YES
32 2.5 x 6	D1	2.46	5.95	1.79	1.21	1.37	4.87	0.98	4.51	0.81	YES
32 2.25 x 3.87	D1	2.18	3.84	1.50	0.95	1.34	2.98	1.14	2.73	0.43	YES
32 2 x 3.25L	D5	2.00	3.25	3.38	2.81	1.50	2.75	0.53	2.07	2.46	YES
32 2 x 3.5	D1	2.00	3.50	1.38	0.61	1.50	3.25	0.75	2.25	0.50	YES
32 1.5 x 3.87	D1	1.50	3.84	1.48	0.79	1.50	3.62	0.84	3.18	0.31	YES
32 1.5 x 2.75D2	D2	1.50	2.75	1.70	1.08	0.86	2.11	2.11	0.86	0.84	YES
32 1.5 x 2.75	D1	1.46	2.73	1.39	0.64	0.85	2.12	0.85	2.12	0.50	YES
32 1.3 x 3.05	D1	1.25	3.00	0.87	0.71	0.75	2.50	0.90	2.62	0.37	NO
32 1.25 x 2.5	D1	1.25	2.46	1.28	0.64	0.75	2.00	0.64	1.87	0.39	YES
32 1.25 x 2.5D2	D2	1.25	2.50	1.71	1.04	0.75	2.00	0.47	1.72	0.14	YES
32 1 x 13	D2	1.00	13.00	1.07	0.57	1.00	13.00	0.73	12.75	0.43	YES
188B1	D2	1.00	4.50	1.31	0.94	1.00	4.50	0.41	3.91	0.70	YES
32 .75 x 5	D2	0.75	5.00	0.94	0.43	0.75	5.00	0.59	4.25	0.34	YES
188C1	D1	0.75	2.87	0.70	0.56	0.75	2.89	0.35	2.50	0.39	NO
32 .62 x 1.87	D1	0.62	1.87	0.55	0.32	0.43	1.68	0.26	1.50	0.46	NO

When ordering, please specify thread size.